

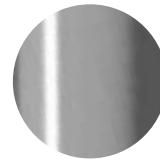

The Australian designed and manufactured **Autoflo Integrated Goose-Neck** Sensor Tap Lead Free is suitable for a range of hand-washing applications, particularly in public commercial areas that experience high traffic and therefore high usage, meaning conservation of water is of paramount importance. The 6-star WELS rating ensures hygienic bathroom environments for users, delivered economically and in an environmentally sensitive fashion.

The robust construction, sleek design is complemented by a range of features ensuring consistent performance. The ability to self-range to its environment, the hygienic self-flush performed every 24-72 hours are just some of what sets the **Autoflo Integrated Goose-Neck** Sensor Tap Lead Free apart from other visually similar taps on the market.

CHROME

Mains 100-5156LF
Battery 100-5162LF

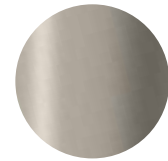
BRUSHED NICKEL

Mains 100-5157LF
Battery 100-5163LF

FEATURES

- Pre-programmed adjustable range
- Long battery life of 3-4 years
- Self-flushing every 24-72 hours
- Simple installation
- Dual stage water filter
- Suitable for high end applications

SPECIFICATIONS

- TAP BODY - Solid brass plated
- SENSOR OPERATION - IR Sensor
- SENSOR RANGE - 140mm factory set
- OPERATING SUPPLY - 240V Mains or 6V Battery
- OPERATING PRESSURE - 150 to 500kPa
- FLOW RATING - 4.5 litres per minute, WELS 6 Star
- SOLENOID - Latching / Soft-closing
- MAX TEMPERATURE - 50°C
- Suitable for tempered water

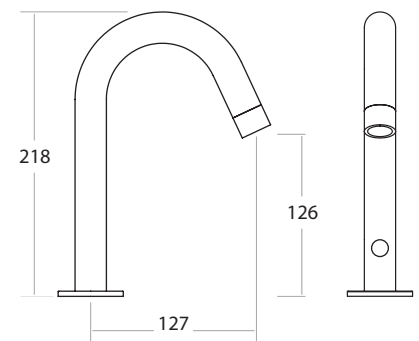
DIMENSIONS

Every effort is made to ensure specifications are correct at the time of printing. Autoflo Pty Ltd reserves the right to make changes without prior notice. All measurements are shown in millimetres.